

# CONQUEST MY530B FLOOR SCRUBBER OPERATOR MANUAL

T: 1800 826 789

E: [support@conquestequipment.com.au](mailto:support@conquestequipment.com.au)

W: [conquestequipment.com.au](http://conquestequipment.com.au)

---

The descriptions contained in this document are not binding.  
The company therefore reserves the right to make any modifications at any time to elements, details, or accessory supply, as considered necessary for reasons of improvement or manufacturing/commercial requirements.  
The reproduction, even partial, of the text and drawings contained in this document is prohibited by law.

---

The company reserves the right to make any technical and/or supply modifications. The images are for reference purposes only, and are not binding in terms of design and supply.

---

### Symbols used in the manual

---



Open book symbol with an "i"  
Indicates the need to consult the instruction manual

---

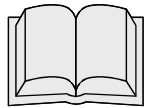

Open book symbol  
Used to tell the operator to read the manual before using the machine

---



Warning symbol  
Carefully read the sections marked with this symbol and comply with the specifications for the safety of the operator and the machine

---



Disposal symbol:  
Carefully read the sections marked with this symbol for disposal of the machine or parts of it

---



Warning symbol  
Indicates danger of gas exhalation and leakage of corrosive liquids

---



Warning symbol  
Indicates the danger of fire  
Do not go near with free flames

---



Warning symbol  
Indicates that the packed product should be handled with suitable lifting means that comply with the legal requirements

---



## CONTENTS

<b>ON CONSIGNMENT OF THE MACHINE</b> .....	<b>4</b>
<b>SERIAL NUMBER PLATE</b> .....	<b>4</b>
<b>INTRODUCTION</b> .....	<b>4</b>
<b>INTENDED USE</b> .....	<b>ERRORE. IL SEGNA LIBRO NON È DEFINITO.</b>
<b>TECHNICAL DESCRIPTION</b> .....	<b>5</b>
<b>GENERAL SAFETY REGULATIONS</b> .....	<b>8</b>
<b>MACHINE PREPARATION</b> .....	<b>9</b>
1. INTENDED USE.....	9
2. HANDLING THE PACKAGED MACHINE.....	9
3. HOW TO UNPACK THE MACHINE.....	9
<b>MACHINE PREPARATION</b> .....	<b>10</b>
4. HOW TO MOVE THE MACHINE.....	10
5. TYPE OF BATTERY (FOR B SYSTEM ONLY).....	10
6. BATTERY MAINTENANCE AND DISPOSAL (FOR B SYSTEM ONLY).....	10
<b>MACHINE PREPARATION</b> .....	<b>11</b>
7. FITTING/CONNECTION OF THE BATTERY (FOR SYSTEM B ONLY).....	11
<b>MACHINE PREPARATION</b> .....	<b>12</b>
8. BATTERY CHARGER (FOR SYSTEM B ONLY).....	12
<b>MACHINE PREPARATION</b> .....	<b>13</b>
9. CONNECTION OF THE ELECTRICAL POWER SUPPLY CONNECTOR (FOR SYSTEM B ONLY).....	13
10. CHARGING THE BATTERY WITH BUILT-IN BATTERY CHARGER (OPTIONAL SYSTEM B).....	13
<b>MACHINE PREPARATION</b> .....	<b>14</b>
11. BATTERY CHARGE LEVEL INDICATOR (SYSTEM B).....	14
<b>MACHINE PREPARATION</b> .....	<b>15</b>
12. HOUR COUNTER INDICATOR (OPTIONAL SYSTEM B).....	15
13. SOLENOID VALVE CONTROL SWITCH (OPTIONAL SYSTEM E).....	15
14. INSTRUMENT PANEL COMPONENTS.....	15
15. REAR COMPONENTS.....	15
16. FRONT COMPONENTS.....	16
17. ASSEMBLING THE SQUEEGEE.....	16
18. ADJUSTING THE SQUEEGEE INCLINATION.....	16
<b>MACHINE PREPARATION</b> .....	<b>17</b>
19. ADJUSTING THE SQUEEGEE HEIGHT.....	17
20. RECOVERY TANK.....	17
<b>MACHINE PREPARATION</b> .....	<b>18</b>
21. SOLUTION TANK / DETERGENT SOLUTION.....	18
22. BASE SPLASH GUARD RUBBER ASSEMBLY (SINGLE BRUSH VERSION).....	18
<b>MACHINE PREPARATION</b> .....	<b>19</b>
23. BASE SPLASH GUARD RUBBER ASSEMBLY (DUAL BRUSH VERSION).....	19
24. BRUSH ASSEMBLY (SINGLE BRUSH VERSION).....	19
25. BRUSH ASSEMBLY (DUAL BRUSH VERSION).....	20
26. REGULATING THE SOLUTION.....	20
<b>MACHINE PREPARATION</b> .....	<b>21</b>
<b>WORK</b> .....	<b>22</b>
1. PREPARATION FOR WORK (SYSTEM B).....	22
<b>WORK</b> .....	<b>23</b>
2. PREPARATION FOR WORK (SYSTEM E).....	23
<b>WORK</b> .....	<b>24</b>
2. FORWARD MOVEMENTS.....	24
3. OVERFLOW DEVICE.....	24
<b>AT THE END OF THE WORK</b> .....	<b>25</b>
1. AT THE END OF THE WORK.....	25
<b>DAILY MAINTENANCE</b> .....	<b>26</b>
1. CLEANING THE RECOVERY TANK.....	26
2. CLEANING THE SUCTION FILTER.....	26
3. DISASSEMBLING AND CLEANING THE SQUEEGEE.....	27
4. DISASSEMBLING THE BRUSH (SINGLE BRUSH BASE).....	27
4. DISASSEMBLING THE BRUSH (DUAL BRUSH BASE).....	28
5. CLEANING OF THE SOLUTION DISCHARGE FILTER.....	28
<b>WEEKLY MAINTENANCE</b> .....	<b>29</b>
1. CLEANING THE SQUEEGEE TUBE.....	29
2. CLEANING THE SOLUTION TANK.....	29
3. REPLACING THE SQUEEGEE RUBBERS.....	30
<b>TROUBLESHOOTING</b> .....	<b>31</b>
1. INSUFFICIENT WATER ON THE BRUSH.....	31
2. THE MACHINE DOES NOT CLEAN WELL.....	31
3. THE SQUEEGEE DOES NOT DRY PERFECTLY.....	31
4. EXCESSIVE FOAM PRODUCTION.....	31
6. ELECTRICAL FUSES AND THERMAL PROTECTIONS (SYSTEM E).....	31
<b>DISPOSAL</b> .....	<b>32</b>
<b>CHOOSING AND USING THE BRUSHES</b> .....	<b>33</b>
<b>EC DECLARATION OF CONFORMITY</b> .....	<b>34</b>
<b>EC DECLARATION OF CONFORMITY</b> .....	<b>35</b>



---

### On consignment of the machine

---

When the machine is delivered to the customer, an immediate check must be performed to ensure all the material mentioned in the shipping documents has been received, and also to check the machine has not been damaged during transportation. If this is the case, the carrier must ascertain the extent of the damage at once, informing our customer service office. It is only by prompt action of this type that the missing material can be obtained, and compensation for damage successfully claimed.

---

### Serial number plate

---

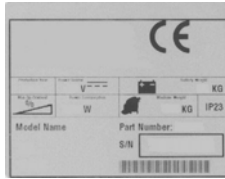

---

### Introduction

---

Minny is a floor scrubbing machine which, via the mechanical action of the rotating brush and the chemical action of a water/detergent solution, can clean any type of flooring. As it advances, it also collects the dirt removed and the detergent solution not absorbed by the floor.

**The machine must only be used for this purpose.** Even the best machines will only work well if used correctly and kept in good working order. We therefore suggest you read this instruction booklet carefully and read it again whenever difficulties arise while using the machine. If necessary, remember that our customer assistance service (organised in collaboration with our dealers) is always available for advice or direct intervention.



TECHNICAL DESCRIPTION	UM	Mিনny 420B	Mিনny 430B	Mিনny 520B	Mিনny 530B
Rated power	W	770	770	770	770
Power supply voltage	V	24	24	24	24
Frequency	Hz	-	-	-	-
Working width	mm	420	430	510	510
Width of rear squeegee	mm	660	660	660	755
Work capacity	m <sup>2</sup> /h	1200	1350	1350	1750
Brush diameter	∅ mm	210 (x2)	420 (x1)	255 (x2)	510 (x1)
Brush rotations	rpm	340	140	275	140
Pressure on the brushes	kg	20	20	22	20
Brush motor	V / W	24/400	24/400	24/400	24/400
Forward speed type		Semi-aut.	Semi-aut.	Semi-aut.	Semi-aut.
Maximum gradient	%	2%	2%	2%	2%
Forward speed	km/h	3.5	3.5	3.5	3.5
Suction motor	W	370	370	370	370
Suction vacuum	mbar	100	100	100	100
Traction motor	V / W	-	-	-	-
Solution tank PE	l	36	36	36	36
Recovery tank PE	l	40	40	40	40
Gross weight of the machine ready for use	kg	112	112	115	115
Batteries	V / AhC5	24/50 - 70	24/50 - 70	24/50 - 70	24/50 - 70
Battery weight	kg	42	42	42	42
Battery compartment dimensions (Length / Height / Width)	mm / mm / mm	360x330x250			
Machine dimensions (Length / Height / Width)	mm / mm / mm	1060x960x455	1060x960x455	1060x960x565	1060x960x555
Noise level (in compliance with IEC 704/1)	dB (A)	67	67	67	67
Vibration level	m/s <sup>2</sup>	1.00	1.00	1.00	1.00

TECHNICAL DESCRIPTION	UM	Mিনny 430E	Mিনny 500E	Mিনny 530E
Rated power	W	900	1200	900
Power supply voltage	V	230	230	230
Frequency	Hz	50	50	50
Working width	mm	420	510	500
Width of rear squeegee	mm	660	660	660
Work capacity	m <sup>2</sup> /h	1200	1350	1350
Brush diameter	∅ mm	420 (x1)	510 (x1)	510 (x1)
Brush rotations	rpm	140	240	140
Pressure on the brushes	kg	20	20	20
Brush motor	V / W	230/450	230/750	230/450
Type of advance		Semi-aut.	Semi-aut.	Semi-aut.
Maximum gradient	%	2%	2%	2%
Forward speed	km/h	3.5	3.5	3.5
Suction motor	W	450	450	450
Suction vacuum	mbar	100	100	100
Traction motor	V / W	-	-	-
Solution tank PE	l	36	36	36
Recovery tank PE	l	40	40	40
Gross weight of the machine ready for use	kg	112	115	115
Batteries	V / AhC5	-	-	-
Battery weight	kg	-	-	-
Battery compartment dimensions (Length / Height / Width)	mm / mm / mm	-	-	-
Machine dimensions (Length / Height / Width)	mm / mm / mm	1060x960x455	1060x960x555	1060x960x555
Noise level (in compliance with IEC 704/1)	dB (A)	67	67	67
Vibration level	m/s <sup>2</sup>	1.00	1.00	1.00



## SYMBOLS USED ON THE MACHINE



Solution tap symbol.  
Used on the control panel to indicate that the solution tap is open (version B).



Suction motor symbol.  
Used on the control panel to indicate the suction motor switch.



Brush motor symbol.  
Used on the control panel to indicate the brush motor switch - master switch.



Battery charge level indicator  
Also indicates the position of the tap (off = tap closed, on = tap open)

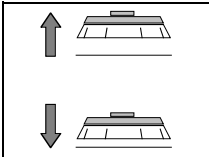

Base raise-lower symbol.  
Used on the rear casing to indicate the base raise-lower lever.

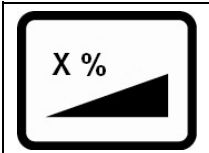

Indicates the maximum gradient

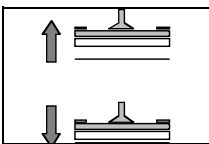

Squeegee raise-lower symbol.  
Used on the rear casing to indicate the squeegee raise-lower lever.



Indicates the maximum temperature of the detergent solution  
Located near the solution tank inlet

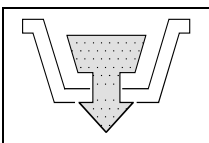

Indicates the recovery tank drainage tube



## SYMBOLS USED ON THE MACHINE



Indicates that there are electrical components nearby that can accumulate residual voltage (E version only)



Represents the voltage indicator light (version E).



Solution tap symbol. Used on the control panel to indicate that the solution tap is open (version E).  
Indicates the control switch in versions with solenoid valve (optional)

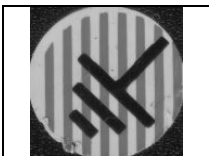

Indicates the machines electrical earthing point (E version only)



## GENERAL SAFETY REGULATIONS

The regulations below must be carefully followed in order to avoid harm to the operator and damage to the machine.

- Read the labels on the machine carefully. Do not cover them for any reason and replace them immediately if they become damaged.
- The machine must be exclusively used by authorised, trained personnel.
- During the working of the machine, pay attention to other people and especially to children.
- The machine is not suitable for cleaning carpets.
- The socket for the battery charger cable must have a prescribed earth connection.
- Avoid damaging the battery charger cable by crushing or bending it, or by applying stress.
- Do not let the power cable come into contact with the rotating brush.
- If the power supply cable is damaged, do not use the machine and contact a **FIMAP** service centre immediately.
- If you notice any damage to the battery charger cable, contact a **FIMAP** technical assistance centre immediately.
- Do not mix different types of detergent as this may produce harmful gases.
- Do not place any liquid containers on the machine.
- The machine is designed for dry use only and should not be used or kept outdoors in damp conditions.
- The storage temperature must be between -25°C and +55°C; do not store outdoors in damp conditions.
- Conditions of use: room temperature between 0°C and 40°C with relative humidity between 30 and 95%.
- Do not use the machine in an explosive atmosphere.
- Do not use the machine as a means of transport.
- Do not use acid solutions which may damage the machine.
- Avoid working with the brushes when the machine is standing still, so as not to damage the floor.
- Do not vacuum inflammable liquids.
- Do not use the device to collect dangerous powders.
- In the event of a fire, use a powder extinguisher. Do not use water.
- Do not knock against shelving or scaffolding, where there is a danger of falling objects.
- If you use the machine where there is a risk of falling objects, the machine must be equipped with protection devices against falling objects.
- Do not use the machine on surfaces with an inclination greater than the one shown on the plate.
- The machine is designed to simultaneously carry out the washing and drying operations. Different operations should only be carried out in areas where the passage of unauthorised persons is prohibited. Signal the presence of damp floors with suitable signs.
- If the machine does not work properly, verify that this is not caused by failure to carry out routine maintenance. Otherwise, request the intervention of the **FIMAP** technical assistance centre.
- If you need to replace any components, request the ORIGINAL spare parts from a **FIMAP** dealer and/or Authorised Retailer.
- For all maintenance interventions, switch off the machine and disconnect the battery connector or the power supply cable.
- Do not remove any protection devices which require the use of tools in order to be removed.
- Do not wash the machine with direct water jets or with pressurised water, nor with corrosive substances.
- Send the machine to a **FIMAP** technical assistance centre for servicing at least once a year.
- To prevent scaling in the solution tank filter, do not fill the tank with detergent solution many hours before using the machine.
- Before using the machine, check that all the hatches and covers are positioned as shown in this Manual.
- When disposing of consumption materials, comply with currently effective laws and regulations.
- When your **FIMAP** machine has reached the end of its long working life, dispose of the materials it contains in an appropriate manner, and bearing in mind that the machine itself was constructed using 100% recyclable materials.
- Only use the brushes supplied with the device, or those specified in the Use and Maintenance Manual (page 29). The use of other brushes could compromise safety levels.
- The device must be disconnected from the power supply before removing the battery.
- The battery must be removed from the device before this is disposed of.
- The battery and battery charger must be disposed of in a safe manner by scrupulously comply with currently effective laws.
- The machine is not suitable for use by children or people with reduced physical, mental and sensorial capacities, or people lacking experience and knowledge, unless supervised and instructed in the use of the machine by a person responsible for their safety.
- Children must be supervised to ensure they do not play with the device.
- The machine must be used mainly in closed environments, and never left outside, in damp areas.
- Check all covers and tanks are correctly fixed on the machine.
- The elements of the batteries used must have a cell voltage no greater than 2.7V.
- Whenever the machine is not being used, apply the emergency brake and turn off the main switch.





## MACHINE PREPARATION

### 1. INTENDED USE

The scrubbing machine is designed exclusively for the professional cleaning of surfaces and floors in industrial, commercial and public environments. In addition, only use the machine in closed (or at least covered) places.

### 2. HANDLING THE PACKAGED MACHINE

The machine is contained within specific packaging.  
It is not possible to place more than two packages on top of each other.  
The overall dimensions of the package are:

	DIMENSIONS
A	1120
B	600
C	1320

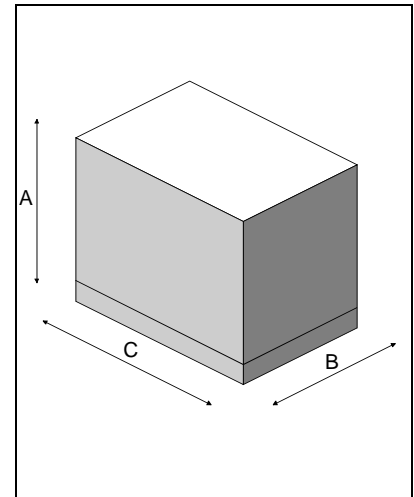

### 3. HOW TO UNPACK THE MACHINE

1. Remove the outer packaging.
2. The machine is fixed to the pallet with a strap, remove it.

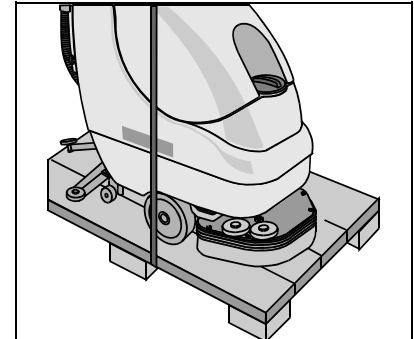

3. Use a chute to get the machine down from the pallet, pushing it backwards. Do not mount the rear squeegee before unloading the machine and avoid violent blows to the brush base. To assemble the squeegee, read the "ASSEMBLING THE SQUEEGEE" paragraph.
4. Keep the pallet for any future transport needs.



**ATTENTION:** if the product is delivered in cardboard containers, handle the packed product with suitable lifting means that comply with the legal requirements.

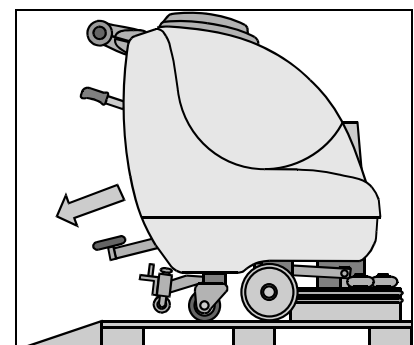



## MACHINE PREPARATION

### 4. HOW TO MOVE THE MACHINE

1. To move the car safely the pallet should preferably be used to support the machine, fixing wooden wedges to the wheels.
2. Lower the squeegee (1) by means of the lever
3. Lower the base (2) by resting the brushes, by means of the lever
4. Secure the machine by using the wheel blocking wedges (3), as shown in the figure.

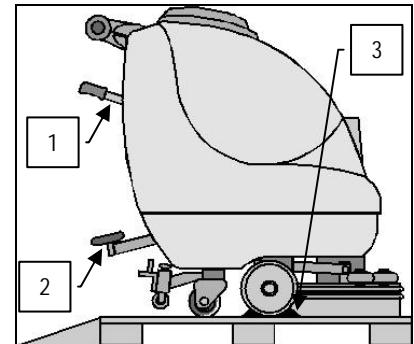

### 5. TYPE OF BATTERY (FOR B SYSTEM ONLY)

To power the machine it is necessary to use:

- liqvidelectrolyte lead traction batteries;
- sealed traction batteries with gasrecombination or gel technology.

The maximum dimensions of each battery are:

- width 195mm
- length 360mm
- height 250mm



OTHER TYPES MUST NOT BE USED.

The batteries used should be monoblock with a voltage of 12V each and with an electrical capacity of 65 Ah

### 6. BATTERY MAINTENANCE AND DISPOSAL (FOR B SYSTEM ONLY)

For maintenance and recharging, comply with the instructions provided by the battery manufacturer. Particular attention must be paid when choosing the battery charger, if not supplied, since there are different kinds according to the type and capacity of the battery.

When the battery reaches the end of its working life, it must be disconnected by expert, trained personnel, then lifted (using the grips and suitable lifting devices) to remove it from the battery compartment. DEAD BATTERIES ARE CLASSIFIED AS DANGEROUS WASTE AND MUST BE DELIVERED TO THE AUTHORISED BODIES FOR CORRECT DISPOSAL.

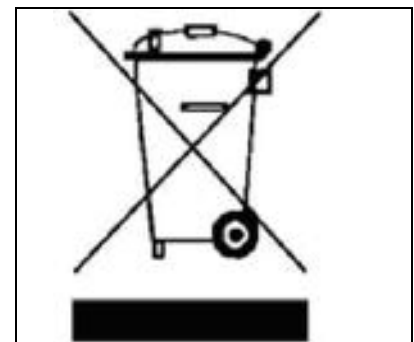



## MACHINE PREPARATION



**WARNING:** you are advised to always wear protective gloves, to avoid the risk of serious injury to your hands



**WARNING:** You are advised to only lift and move the batteries with lifting and transportation means suitable for the specific weight and size

### 7. FITTING/CONNECTION OF THE BATTERY (FOR SYSTEM B ONLY)

The machine can be equipped with integrated battery charger (optional) and batteries included. When using batteries other than those supplied with the machine, have the configuration of the battery charger (optional) and the control board verified by an engineer certified and trained by the FIMAP service centre.

Perform a battery charging cycle before using the machine.

The batteries must be housed in the special compartment beneath the recovery tank.

To insert the batteries you must:

1. Check the recovery tank is empty, otherwise empty it completely.
2. Open the recovery tank cover, bringing it forwards.
3. detach the squeegee tube (1) from the recovery tank
4. unthread the suction cap (2) by rotating it anticlockwise
5. detach the "recovery tank" drainage tube from its hook
6. remove the recovery tank

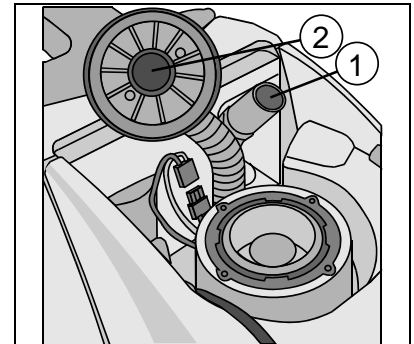

7. Lift the batteries by means of the grips on the upper part
8. house the batteries in the compartment, positioning the poles "+" and "-" opposite each other
9. Connect the batteries in series to the "+" and "-" poles using the supplied jumper cable
10. Connect the battery connector cable to the "+" and "-" poles in order to obtain the terminal voltage of 24V.



## MACHINE PREPARATION



**ATTENTION:** you are advised to use airtight batteries only, to avoid the leakage of acids!

**ATTENTION:** you are advised to have the electric connections made by a qualified, FIMAP trained technician



**WARNING:** you are advised to always wear protective gloves in order to avoid the risk of serious injury to your hands



**WARNING:** You are advised to only lift and move the batteries with lifting and transportation means suitable for the specific weight and size

### 8. BATTERY CHARGER (FOR SYSTEM B ONLY)

In order not to cause permanent damage to the batteries it is essential to avoid their complete discharge: arrange the recharge within a few minutes of the switching on of the flashing "discharged batteries" signal.



**NOTES:** never leave the batteries completely discharged, even if the machine is not being used. While recharging, keep the recovery tank raised, supporting it with the cable, as shown in the figure. Check the battery charger is suitable for the batteries installed, in terms of both capacity and type.

Check the battery charger is suitable for the batteries installed, in terms of both capacity and type (lead/acid or GEL and equivalents).



**ATTENTION:** never charge a GEL battery with an unsuitable battery charger. Follow the instructions given by the battery/battery charger manufacturer with the utmost attention.

Beneath the recovery tank cover there is the battery connector (2), in which the battery charger connector must be inserted. The coupling connector of the battery charger is consigned inside the bag containing this instruction booklet, and must be assembled on the cables of the battery charger as indicated in the instructions.



**WARNING!** This process must be carried out by qualified personnel. The incorrect or imperfect connection of the cables to the connector can cause serious harm to people and damage to objects.

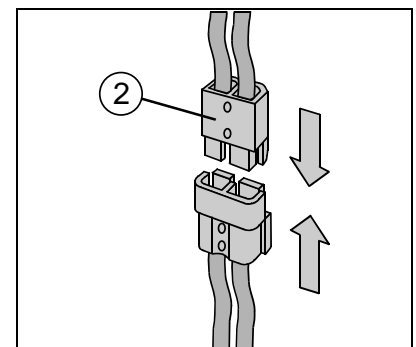



## MACHINE PREPARATION

### 9. CONNECTION OF THE ELECTRICAL POWER SUPPLY CONNECTOR (FOR SYSTEM B ONLY)

The following is required to insert the electrical power supply connector:

1. Check the recovery tank is empty, otherwise empty it completely.
2. Open the recovery tank cover, bringing it forwards.
3. detach the squeegee tube (1) from the recovery tank
4. unthread the suction cap (2) by rotating it anticlockwise
5. detach the "recovery tank" drainage tube from its hook
6. remove the recovery tank

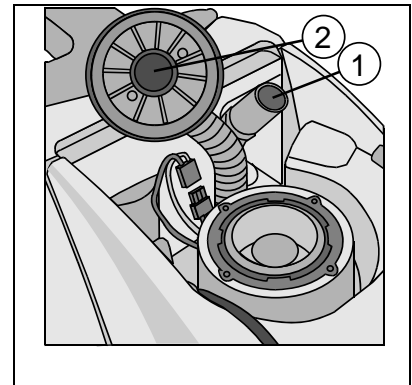

7. Connect the battery connector (2) to the machine connector (1).
8. reassemble all the elements



**ATTENTION:** this is done only once for machines with built-in battery charger, with the exception of maintenance operations

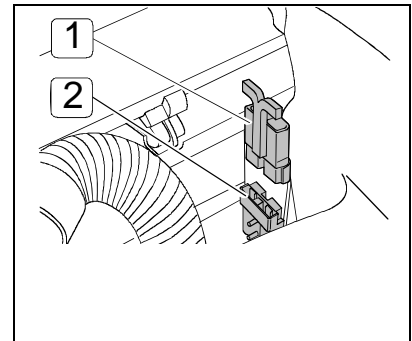

### 10. CHARGING THE BATTERY WITH BUILT-IN BATTERY CHARGER (OPTIONAL SYSTEM B)

The machine does not have a built-in battery charger, an optional kit is subsequently assembled, connect the battery connector to the machine connector (see previous paragraph).

To charge the battery proceed as follows:

1. Lift the battery charger socket guard (1) on the back of the machine.
2. Plug the battery charger cable into the electrical system of the machine.
3. Plug the power supply cable of the charger into the mains socket.

When replacing the battery, be sure to use batteries suitable for the battery charger installed.



**ATTENTION:** the machine is equipped with an automatic system that disconnects the power supply from the electrical system while the batteries are being recharged



## MACHINE PREPARATION



**ATTENTION:** in order not to cause permanent damage to the batteries it is essential to avoid their complete discharge: arrange the recharge within a few minutes of the switching on of the flashing "discharged batteries" signal

**ATTENTION:** never leave the batteries completely discharged, even if the machine is not being used



**WARNING:** for the daily recharging of the batteries, you must fully respect the indications provided by the manufacturer or retailer. All installation and maintenance operations must be carried out by expert personnel, trained at the FIMAP assistance centre

**WARNING** Make sure that the battery charger green LED is on before using the machine again



**ATTENTION:** danger of exhalation of gas and leakage of corrosive liquids



**ATTENTION:** danger of fire: do not go near with free flames

### 11. BATTERY CHARGE LEVEL INDICATOR (SYSTEM B)

The battery indicator is digital, with 4 fixed positions and a flashing one. The numbers which appear on the display show the approximate charge level.

4 = maximum charge, 3 = 3/4 charge, 2 = 2/4 charge, 1 = 1/4 charge,

0 = discharged batteries (flashing)



**WARNING!** A few seconds after the appearance of the flashing "0", the brush motor switches off automatically. With the remaining charge it is possible to complete the drying process before starting the recharge.

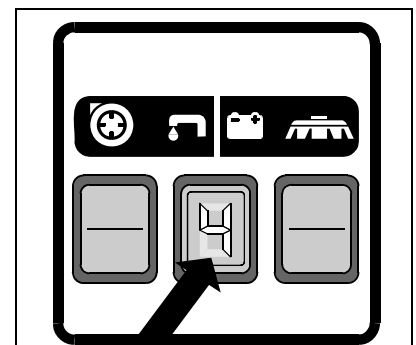



## MACHINE PREPARATION

### 12. HOUR COUNTER INDICATOR (OPTIONAL SYSTEM B)

The machine does not have a built-in hour counter, an optional kit is subsequently assembled. The hour counter indicates the total operating time, the line that appears indicates the hours and minutes of operation. The flashing ":" symbol indicates that the hour-counter is counting the machine functioning time.

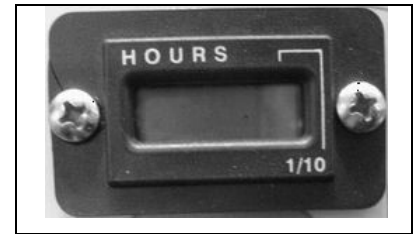

### 13. SOLENOID VALVE CONTROL SWITCH (OPTIONAL SYSTEM E)

The machine does not have a built-in solenoid valve, an optional kit is subsequently assembled. The switch (1) is used to provide power to the solenoid valve, which emits the solution onto the brushes only when consent is given by the man present switch.

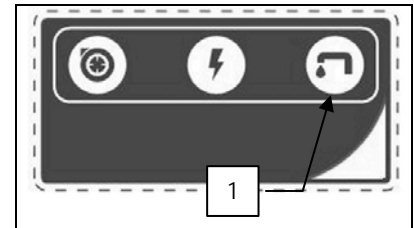

### 14. INSTRUMENT PANEL COMPONENTS

The instrument panel components are identified as follows:

1. Brushes operation lever (man present switch)
2. Switch with green light, used to control the suction motor.
3. Battery level display (version B), green light signal (version E) used to identify that the system is live
4. Switch with green light (version B), is used to control the brushes motor, hole plug (version E). Solenoid valve control switch (optional version E)

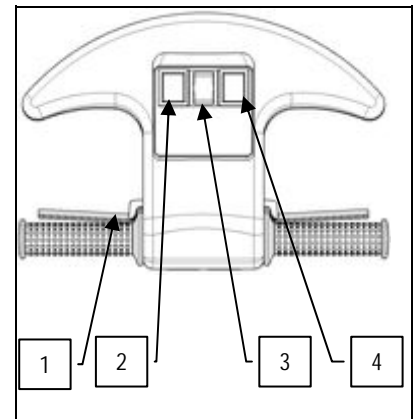

### 15. REAR COMPONENTS

The rear components are identified as follows:

5. Tap control stem
6. Squeegee lifting lever
7. Brush lifting pedal
8. Discharge pipe with recovery tank cap
9. Thermal circuit breaker (system E)

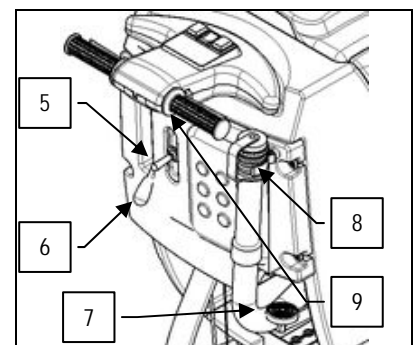

10. Solution tank discharge cap – solution filter

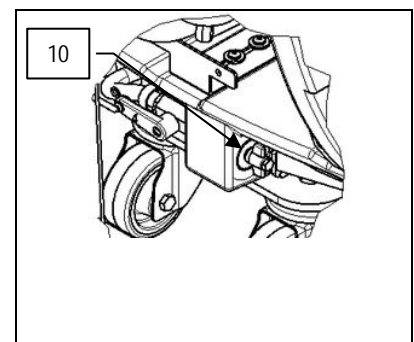



## MACHINE PREPARATION

### 16. FRONT COMPONENTS

The front components are identified as follows:

11. Solution water filler cap
12. Suction unit casing

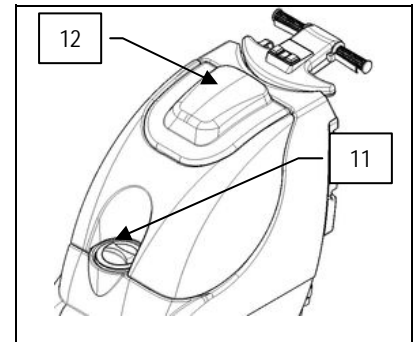

### 17. ASSEMBLING THE SQUEEGEE

For packaging reasons, the squeegee is supplied disassembled from the machine, and must be assembled on the machine connection. The squeegee connector must be lifted by means of the lever at the rear of the machine and perform the procedures outlined below:

1. Check that the main switch of the machine is turned off, and verify that power plug is unplugged from the mains for the electric versions
2. Raise the squeegee and insert the small right-hand column (1) in the connection hole
3. Insert the retaining clip (2)

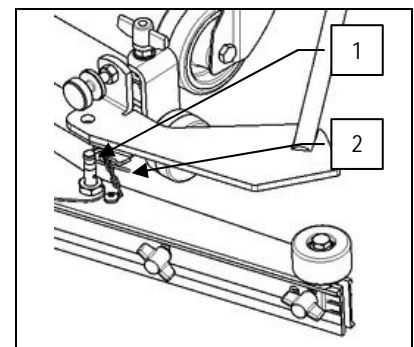

4. Raise the squeegee and insert the small left-hand column (3) in the connection hole
5. insert the retaining clip (2)
6. Insert the suction tube in the appropriate squeegee sleeve (4), ensuring that the tube lies to the right of the lifting cable

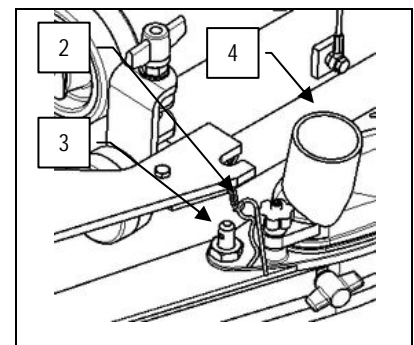

**ATTENTION:** these operations must be carried out using protective gloves to avoid any possible contact with the edges or tips of metal objects

### 18. ADJUSTING THE SQUEEGEE INCLINATION

During movement, the rear rubber should be slightly tilted backwards in a uniform manner at an angle of about 45 degrees to the floor along its entire length of about 5mm.

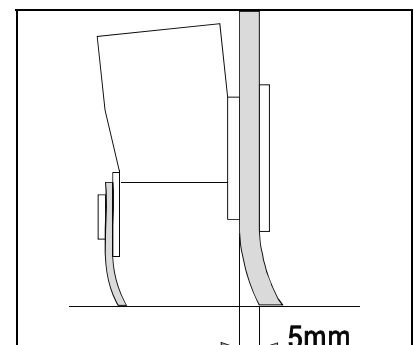





## MACHINE PREPARATION

If it is necessary to increase the bend of the rubber in the central part, you must tilt the squeegee backwards, rotating the adjuster (1) anticlockwise. To increase the bend of the rubber at the sides of the squeegee, rotate the set screw clockwise.

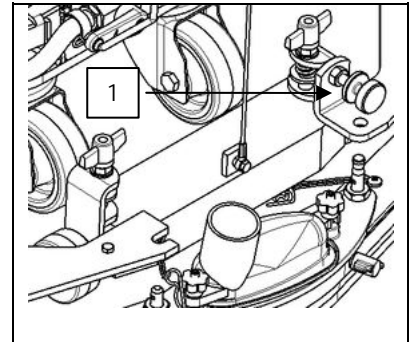

### 19. ADJUSTING THE SQUEEGEE HEIGHT

The height of the squeegee must be adjusted on the basis of the state of wear and tear of the rubber. To do this, turn the knob (2) anticlockwise to raise the squeegee, and clockwise to lower it.

**Remarks:** the right and left wheels must be adjusted to the same level, so the squeegee can work parallel to the floor.

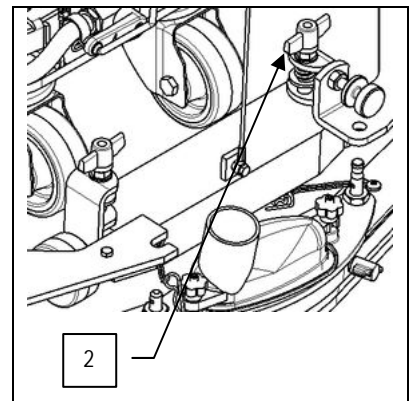

### 20. RECOVERY TANK

Check the recovery tank is empty, otherwise empty it completely.

Open the cover and check the suction cap (2) is correctly blocked (insert the notches in their housings, rotating the cap clockwise) and correctly connected to the tube leading to the suction motor.

In addition, check the squeegee tube (1) is correctly inserted in its housing, and that the drainage tube cap (in the rear part of the machine) is closed.

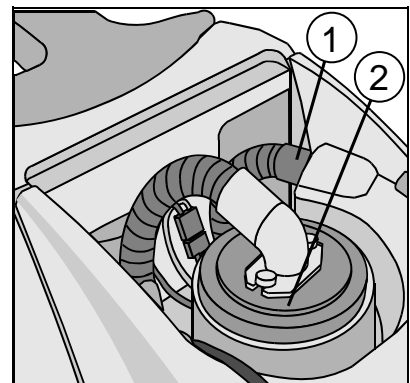

Check the cap of the drainage tube (on the rear of the machine) is correctly closed.



**ATTENTION:** To avoid foam production, put a minimum quantity of antifoam liquid in the recovery tank before starting to clean

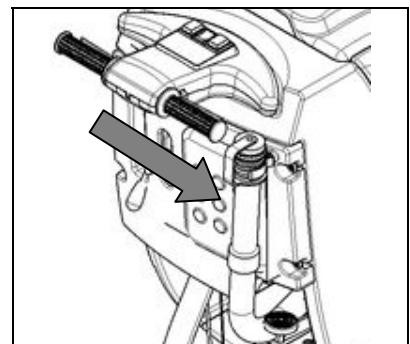



## MACHINE PREPARATION

### 21. SOLUTION TANK / DETERGENT SOLUTION

Completely empty the recovery tank each time the solution tank is filled.  
For electrical machines, check that the power supply cable is unplugged from the mains. Remove the front inlet cap and check the solution filter (1) is correctly assembled.

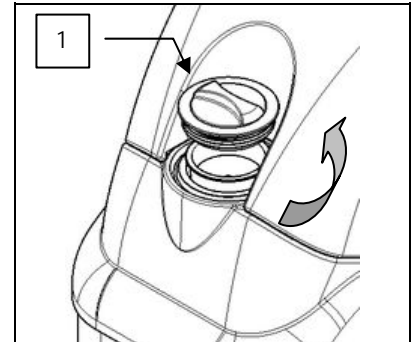

Check the filter cover (2) beneath the solution tank is correctly closed.  
Fill it with clean water at a temperature not exceeding 50°C.  
Add the liquid detergent to the tank in the concentration and manner indicated on the detergent manufacturer's label. The formation of excess foam could damage the suction motor, so use only the minimum amount of detergent necessary.

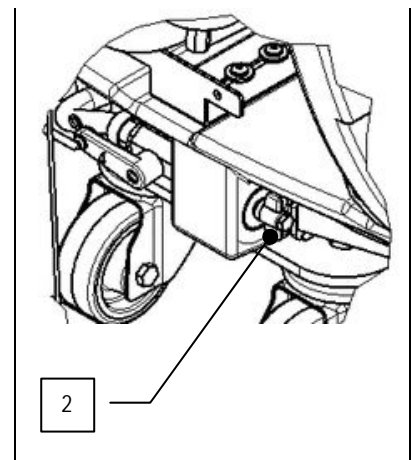

**ATTENTION:** always use detergents whose manufacturer's label indicates their suitability for scrubbing machines. Do not use acid or alkaline products or solvents without this indication.

In addition, you are advised to always use low foam detergents.

Do not use pure acids



Acidic or alkaline maintenance detergents can be used with pH values between 4 and 10 and that are free of: oxidising agents, chlorine or bromine, formaldehyde, mineral solvents.



**ATTENTION:** you are advised to always wear protective gloves, to avoid the risk of serious injury to your hands

### 22. BASE SPLASH GUARD RUBBER ASSEMBLY (SINGLE BRUSH VERSION)

For packaging reasons, the splash guard rubbers are supplied disassembled from the machine. Remove the hook (1) of the spring from the connector screw on the right side of the base, wrap the rubber all around the base and position it so that it is symmetrical to the brush. Replace the previously removed strip securing the hook (1) of the spring in the screw connector.

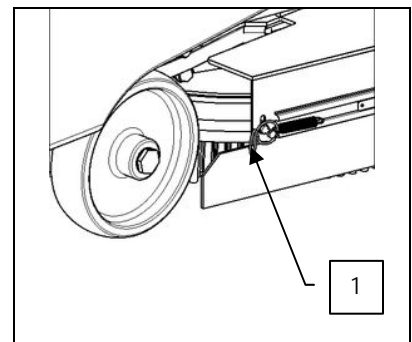



## MACHINE PREPARATION

### 23. BASE SPLASH GUARD RUBBER ASSEMBLY (DUAL BRUSH VERSION)

For packaging reasons, the splash guard rubbers are supplied with the machine. Remove the rubber retaining strips by removing the hook of the spring (1) from the connecting screw. Wrap the rubber around the base inserting the base fixing screw in the centre hole. Reattach the rubber retaining strips starting from the centre of the base, attach the spring (1) of the connecting screw

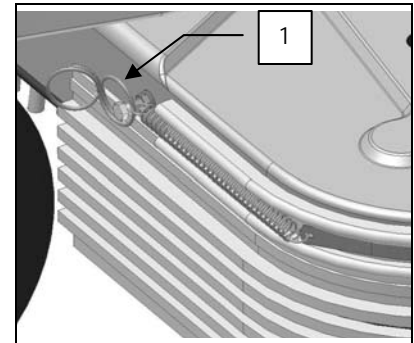

### 24. BRUSH ASSEMBLY (SINGLE BRUSH VERSION)

1. For the electric version, make sure that the power cable of the machine is plugged into the mains socket
2. Activate the main switch of the machine
3. Raise the base by means of the appropriate pedal.
4. With the base up, position the brush in line with the coupling on the machine.
5. Lower the base by means of the pedal.

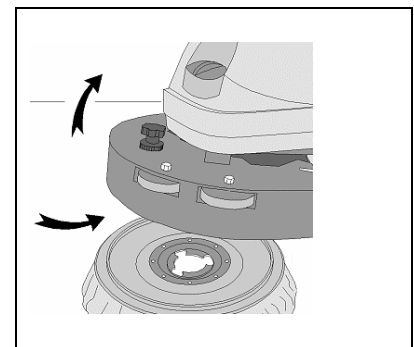

6. Using the "man present" lever (6), the brush is automatically hooked up.



**ATTENTION:** during this operation, check there are no people or objects near the brushes

**ATTENTION:** Check that the power supply voltage and the mains frequency is appropriate with that of the machine (version E).

**ATTENTION:** You are advised to always wear protective gloves, to avoid the risk of serious injury to your hands

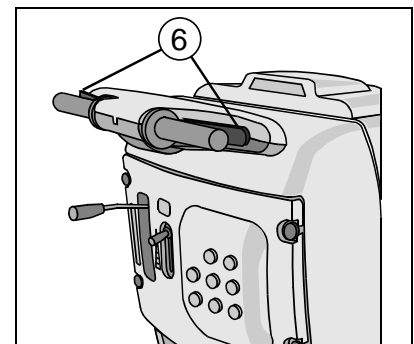

7. To alter the machine forwards speed, use the knob shown in the figure.

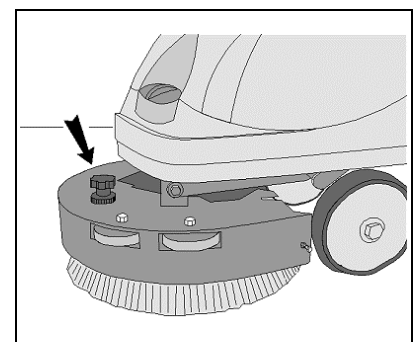



## MACHINE PREPARATION

### 25. BRUSH ASSEMBLY (DUAL BRUSH VERSION)

Proceed as follows to assemble the brushes:

1. Check that the main switch of the machine is turned off, and verify that the power cable is unplugged from the mains (electric versions)
2. Raise the base by means of the appropriate pedal
3. With the base up, place the brushes into the plate housing beneath the base, turning the brushes until the three pins enter the niches in the plate itself; turn until the pin is pushed towards the coupling spring and is locked into place.

The figure shows the rotation direction for coupling the right-hand brush; for the left-hand one, rotate in the opposite direction.

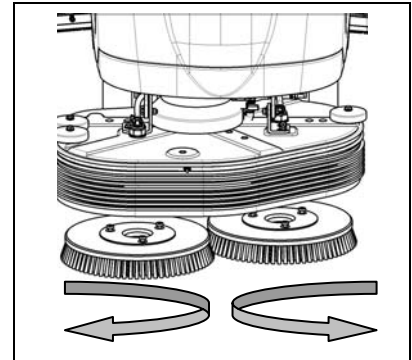

**ATTENTION:** during this operation, check there are no people or objects near the brush.

**ATTENTION:** Make sure the brushes are correctly connected. If this is not the case, the machine could move in an irregular, sudden manner.



**ATTENTION:** you are advised to always wear protective gloves, to avoid the risk of serious injury to your hands

4. You are advised to invert the right and left-hand brushes every day. If the brushes are not new however, and have deformed bristles, it is better to reassemble them in the same position (the right-hand one on the right, and the left-hand one on the left), to prevent the different inclination of the bristles producing an overload on the brush motor as well as excessive vibrations.

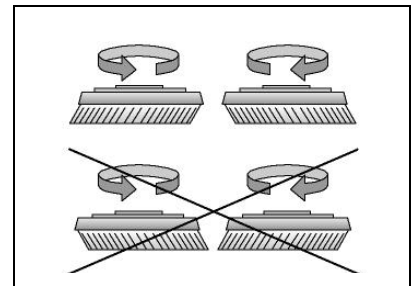

### 26. REGULATING THE SOLUTION

Adjust the amount of water through the tap lever on the back of the machine (1), by pressing the man present levers the brushes are activated and the machine starts moving. During the first few meters check that the amount of solution is sufficient to wet the floor, but not excessive to exit the splash guard. Bear in mind that the correct amount of solution is always depends on the nature of the floor, the degree of dirt and the forward speed.

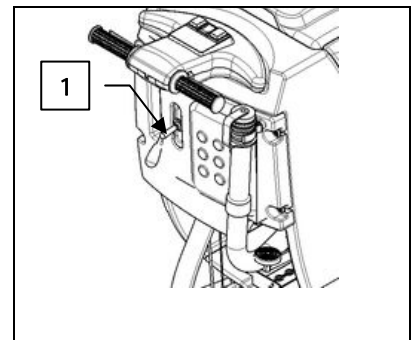



## MACHINE PREPARATION



**ATTENTION:** If after using the machine the tap is left open, the battery level indicator (2) will remain on, to turn it off simply turn off the tap with the appropriate lever, mounted on the rear of the machine. (system B)

**ATTENTION:** Make sure to close the solution tap after using the machine, otherwise the cleaning solution will continue to flow. (system E)

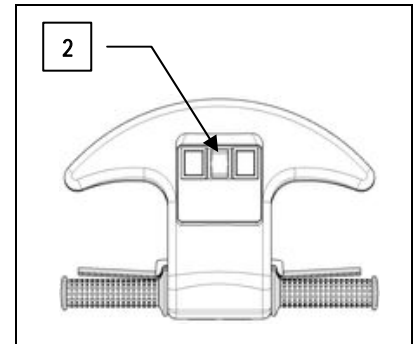



## WORK

### 1. PREPARATION FOR WORK (SYSTEM B)

1. Connect the connector (1) to the batteries (versions B), this is already connected for the versions with the BC already built in, while for the electric versions, connect the power cable to the mains.



**ATTENTION:** before using the machine, the operators must be suitable trained. We therefore suggest you read this instruction booklet carefully and read it again whenever difficulties arise while using the machine

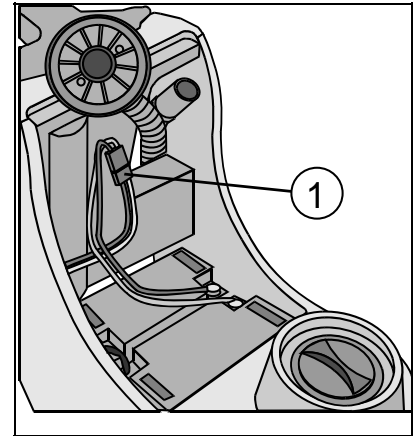

2. Press the brush switch (2)
3. Press the suction motor switch (3)

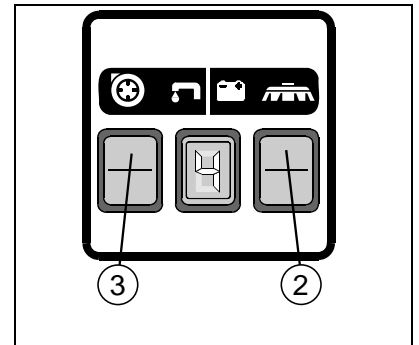

4. Open the water tap with lever (4) on the back of the machine, the water automatically falls during the rotation of the brushes.
5. Lower the squeegee using lever (5) on the back of the machine.



**ATTENTION:** if the machine is used in places where there is a risk of falling objects, the operator must be provided with all the appropriate protection devices as laid out in the legal requirements

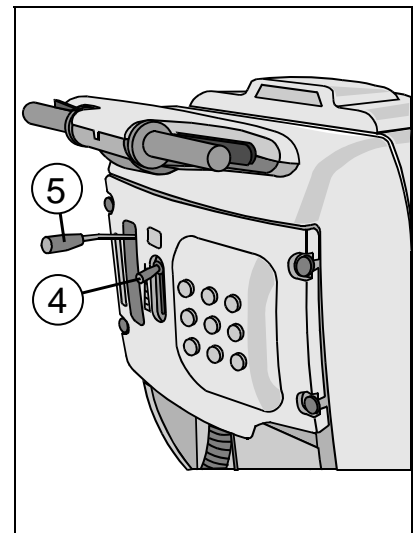



## WORK

6. Via the "man present" lever (6), the brushes begin to rotate and the squeegee begins to suck in.
7. During the first metres, check there is sufficient solution and that the squeegee dries perfectly.

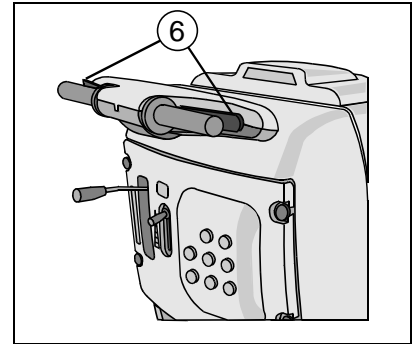

### 2. PREPARATION FOR WORK (SYSTEM E)

1. Plug the machine's power supply plug into the mains power supply, the power present light (1) will light immediately



**ATTENTION:** before using the machine, the operators must be suitable trained. We therefore suggest you read this instruction booklet carefully and read it again whenever difficulties arise while using the machine

2. Press the suction motor switch (2)
3. Press the solenoid valve switch (3), if present on the machine (optional)

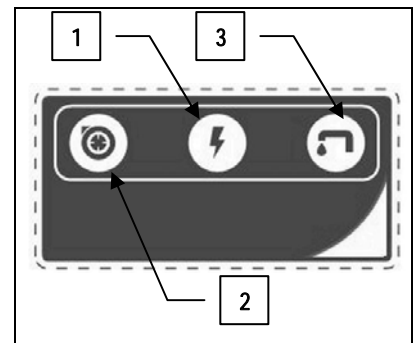

4. Open the water tap with lever (4) on the back of the machine, the water automatically falls during the rotation of the brushes.
5. Lower the squeegee using lever (5) on the back of the machine.



**ATTENTION:** If the solution tap is left open after using the machine the solution will continue being emitted, this problem does not exist for versions with solenoid valve

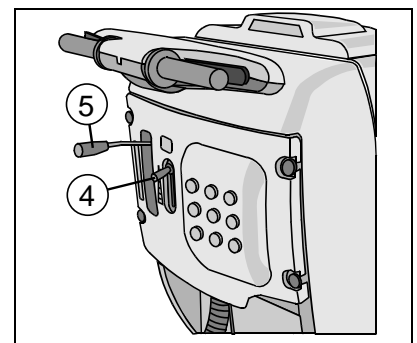

**ATTENTION:** if the machine is used in places where there is a risk of falling objects, the operator must be provided with all the appropriate protection devices as laid out in the legal requirements



## WORK

6. By activating the man present lever (6) the brushes begin to rotate and the squeegee starts suction, in the versions with the solenoid valve only now is the solution emitted onto the brush.
7. During the first metres, check there is sufficient solution and that the squeegee dries perfectly.

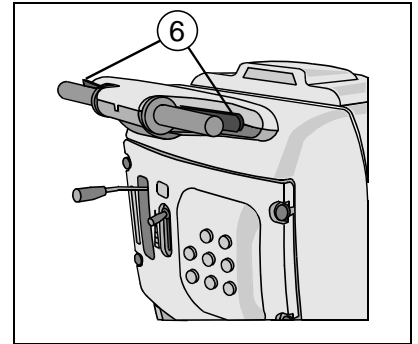

### 2. FORWARD MOVEMENTS

The traction of these machines is obtained by means of the brush which, working slightly inclined, is able to drag the machine forwards. The brush has to be lifted in order to move the machine by means of the grip on the handlebar.



**ATTENTION!** When making even brief reverse movements, check the squeegee is raised.

### 3. OVERFLOW DEVICE

The machine is fitted with a float which intervenes when the recovery tank is full, causing the suction tube to close. In this case the recovery tank must be emptied by removing the cap of the rear discharge pipe



**ATTENTION:** you are advised to always wear protective gloves, to avoid the risk of serious injury to your hands

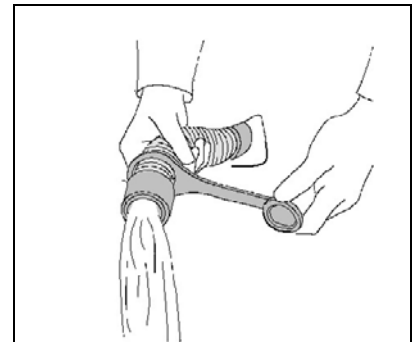





## AT THE END OF THE WORK

### 1. AT THE END OF THE WORK

At the end of the work, and before carrying out any type of maintenance:

1. turn off the tap by means of the lever (1)
2. Raise the base by means of the pedal
3. raise the squeegee by means of the lever (2)

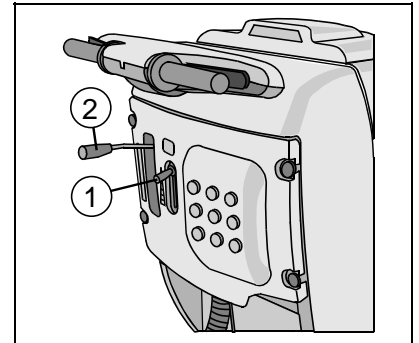

4. Turn off the suction motor switch (4)
5. Turn off the brush motor switch (3)
6. Disconnect the plug from the mains socket, for electric versions only

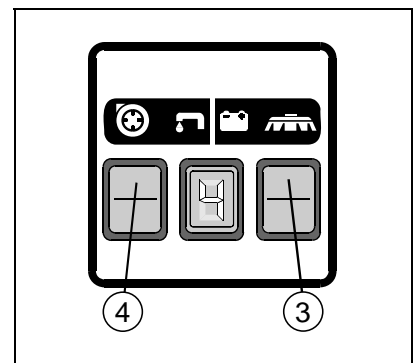

**ATTENTION!** If the battery indicator display is still switched on after you have turned off the brush switch (3), this means the tap is turned on: turn off the tap via the lever (1) to prevent detergent solution leaking out. (SYSTEM B)

7. bring the machine to the place provided for draining the water

8. grasp the tube on the rear of the machine
9. Remove the drainage cap and empty the tank.



**ATTENTION:** you are advised to always wear protective gloves, to avoid the risk of serious injury to your hands

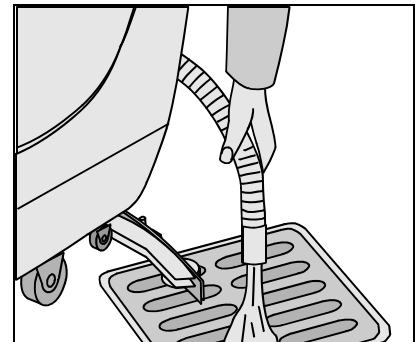

10. disassemble the brush and clean it with a jet of water (to disassemble the brush, see "DISASSEMBLING THE BRUSH" below)



**ATTENTION:** Do not park the machine in open spaces or on sloping floors.

11. The squeegee and the base must be off the ground when the machine is not operating to prevent deforming the squeegee and brush.
12. After work, park the machine indoors, on a flat and level surface; objects that can damage or be damaged through contact with the machine must not be present close to the machine.



## DAILY MAINTENANCE

PERFORM ALL MAINTENANCE OPERATIONS IN SEQUENCE

### 1. CLEANING THE RECOVERY TANK

1. Check that the main switch of the machine is turned off, and verify that machine's power cable is unplugged from the mains (electric versions)
2. Lift the recovery tank lid
3. Unthread the suction cap (1) by rotating it anticlockwise
4. Remove the filter and related protection
5. rinse the tank with a water jet

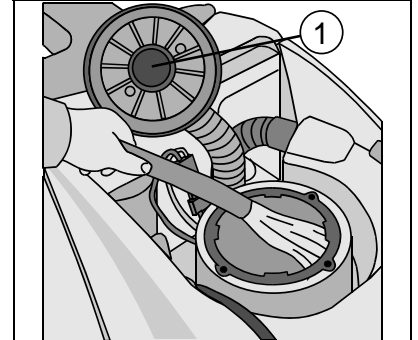

**WARNING:** you are advised to always wear protective gloves in order to avoid the risk of serious injury to your hands

### 2. CLEANING THE SUCTION FILTER

1. Check that the main switch of the machine is turned off, and verify that machine's power cable is unplugged from the mains (electric versions)
2. Lift the recovery tank lid
3. Unthread the suction cap by rotating it anticlockwise
4. Unthread the filter
5. Use a jet of water to clean the walls and base of the filter.
6. Carry out the cleaning operations carefully
7. reassemble all the elements.

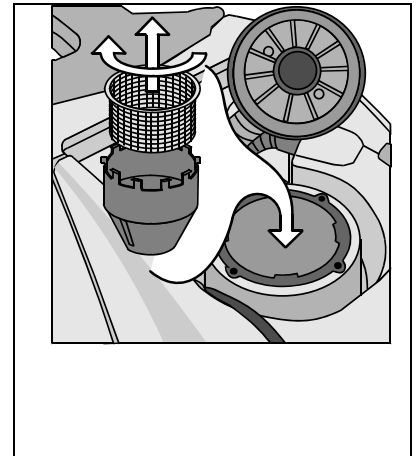

**ATTENTION:** It is advisable to disconnect the battery connector (version B) or disconnect the power plug from the mains (version E) before proceeding with any activity.



**WARNING:** you are advised to always wear protective gloves in order to avoid the risk of serious injury to your hands



## DAILY MAINTENANCE

### 3. DISASSEMBLING AND CLEANING THE SQUEEGEE

Check the squeegee is always clean, for better drying results.

To clean it you must:

1. Check that the main switch of the machine is turned off, and verify that machine's power cable is unplugged from the mains for the electric versions
2. remove the tube (1) from the squeegee
3. Remove the squeegee by disconnection the pins (2) in order to release the squeegee stud from its seat.
4. Pull the squeegee downwards
5. Thoroughly clean the inside of the squeegee and and its suction inlet, by loosening the knobs (3)
6. carefully clean the squeegee rubbers
7. reassemble all the elements.

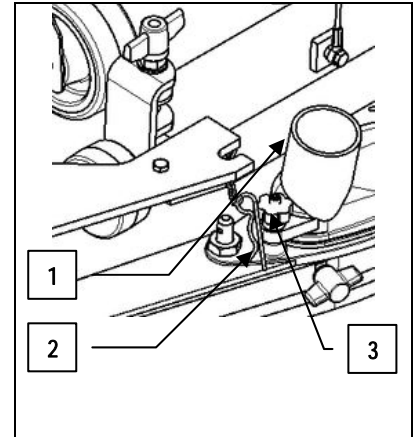

**ATTENTION:** It is advisable to disconnect the battery connector (version B) or disconnect the power plug from the mains (version E) before proceeding with any activity.

### 4. DISASSEMBLING THE BRUSH (SINGLE BRUSH BASE)

1. Raise the base by means of the pedal, do not bring it up to its maximum otherwise it will activate the microswitch which stops the motor.
2. With the base up, use the "man present" lever to automatically release the brush



**ATTENTION!** during this operation, check there are no people or objects near the brush.

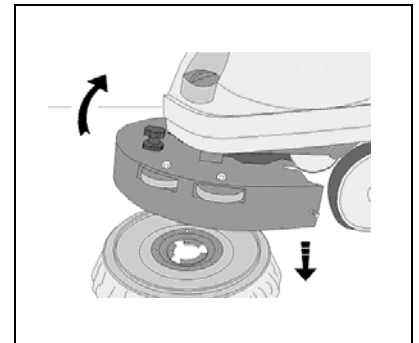

3. Always check the bristles for signs of wear. You are advised to replace the brushes when the bristles are less than 15 mm long



**ATTENTION:** you are advised to always wear protective gloves, to avoid the risk of serious injury to your hands



**WARNING:** during this operation, verify that there are no people or objects near the brush.



## DAILY MAINTENANCE

### 4. DISASSEMBLING THE BRUSH (DUAL BRUSH BASE)

1. Check that the main switch of the machine is turned off, and verify that the machine's power cable is unplugged from the mains (electric versions)
2. raise the base, using the lever
3. With the base up, rotate the brush until it comes out of the brush-holder plate seat, as shown in the figure. The figure shows the rotation direction to release the right-hand brush; for the left-hand one, rotate in the opposite direction
4. Always check the bristles for signs of wear. You are advised to replace the brushes when the bristles are less than 15 mm long

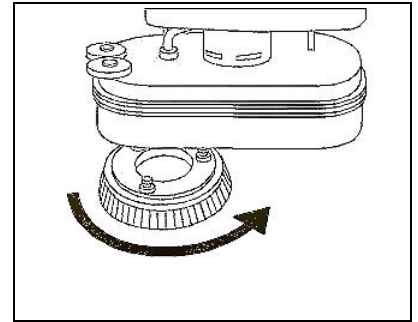

**ATTENTION:** you are advised to always wear protective gloves, to avoid the risk of serious injury to your hands

### 5. CLEANING OF THE SOLUTION DISCHARGE FILTER

1. Check that the main switch of the machine is turned off, and verify that the machine's power cable is unplugged from the mains for (electric versions)
2. Make sure that the solution tank is empty
3. Loosen the filter on the lower rear side of the machine
4. Rinse with a jet of water
5. reassemble all the elements.



**ATTENTION:** you are advised to always wear protective gloves, to avoid the risk of serious injury to your hands

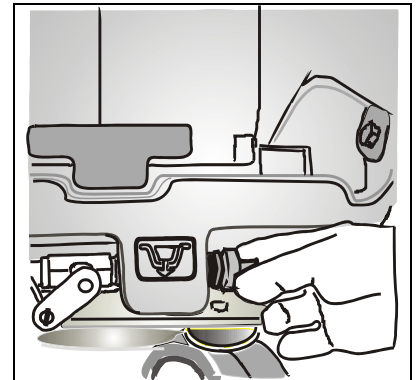

**ATTENTION:** It is advisable to disconnect the battery connector (version B) or disconnect the power plug from the mains (version E) before proceeding with any activity.



## WEEKLY MAINTENANCE

### PERFORM ALL MAINTENANCE OPERATIONS IN SEQUENCE

#### 1. CLEANING THE SQUEEGEE TUBE

Check that the squeegee tube is not blocked weekly or in the event of insufficient suction. If cleaning is required, proceed as follows:

1. Check that the main switch of the machine is turned off, and verify that the machine's power cable is unplugged from the mains (electric versions)
2. Check the recovery tank is empty, otherwise empty it completely.
3. Unthread the tube from the sleeve on the squeegee
4. Remove the other end from the recovery tank



**ATTENTION:** It is advisable to disconnect the battery connector (version B) or disconnect the power plug from the mains (version E) before proceeding with any activity.



**ATTENTION:** you are advised to always wear protective gloves, to avoid the risk of serious injury to your hands

5. Wash the inside of the tube with a water jet introduced from the side where it is connected to the tank
6. To reassemble the tube, repeat the above-mentioned operations in the reverse order



**ATTENTION:** Do not wash the tube running between the suction unit and the suction cap.

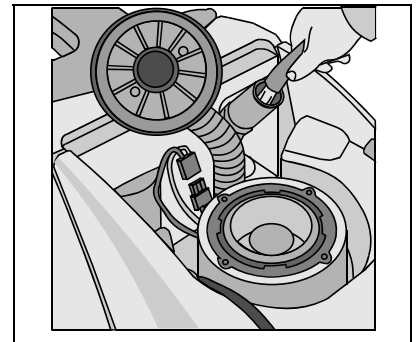

#### 2. CLEANING THE SOLUTION TANK

1. Check that the main switch of the machine is turned off, and verify that the machine's power cable is unplugged from the mains (electric versions)
2. Check the recovery tank is empty, otherwise empty it completely.
3. Loosen the front cap of the solution tank

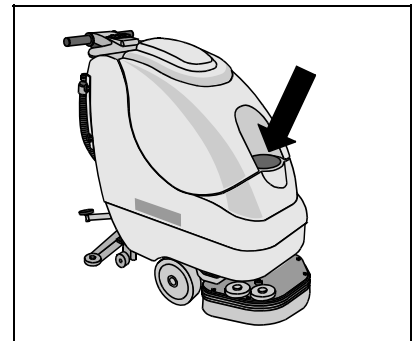

**ATTENTION:** It is advisable to disconnect the battery connector (version B) or disconnect the power plug from the mains (version E) before proceeding with any activity.



## WEEKLY MAINTENANCE

4. Loosen the wing nut of the drainage cap (1) to the left of the tank, and remove the cap
5. Rinse the inside of the tank with a jet of water
6. Insert the cap in the tank, and retighten the wing nut (1)



**ATTENTION:** you are advised to always wear protective gloves, to avoid the risk of serious injury to your hands

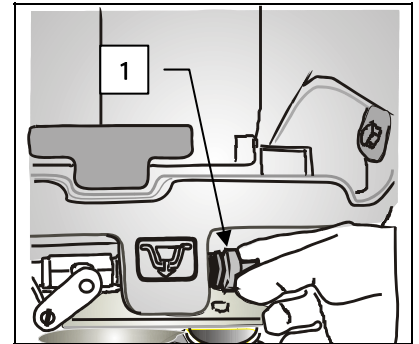

### 3. REPLACING THE SQUEEGEE RUBBERS

Check the state of wear and tear of the squeegee rubbers and, if necessary, replace them. The rear rubber (1) should be replaced when the squeegee fails to pick up well, leaving water on the floor. To replace the rubber, you must:

1. Check that the main switch of the machine is turned off, and verify that the machine's power cable is unplugged from the mains (electric versions)
2. loosen the wing nuts (2) that block the rear rubber-pressing blade and the strengthening profile
3. unthread the rear rubber and replace it (if the rear rubber isn't yet worn, rotate it by 180° and reassemble it so the contact surface is still in good condition)
4. reassemble the rear rubber, the strengthening profile and the rubber-pressing blade, then tighten the wing nuts

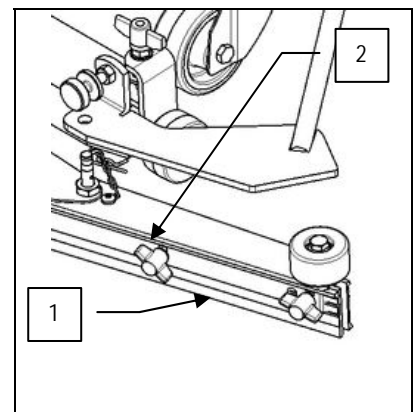

The front rubber (3) should be replaced when the squeegee does not rest evenly on the floor and does not generate a closed suction chamber (letting a lot of air enter from the front). To replace the rubber, you must:

1. disassemble the squeegee from its support (see the "DISASSEMBLING AND CLEANING THE SQUEEGEE" paragraph)
2. loosen the threaded nuts (4) that block the front rubber-pressing blade
3. unthread the front rubber (3) and replace it
4. reassemble the front rubber (3) and the rubber-pressing blade, then tighten the threaded nuts (4)

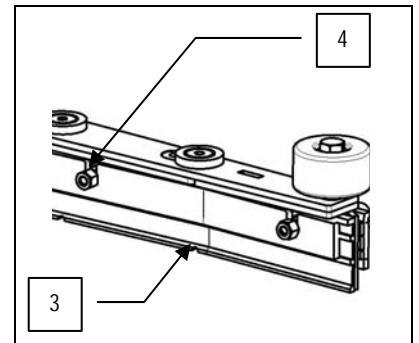

**ATTENTION:** you are advised to always wear protective gloves, to avoid the risk of serious injury to your hands



**ATTENTION:** It is advisable to disconnect the battery connector (version B) or disconnect the power plug from the mains (version E) before proceeding with any activity.



## TROUBLESHOOTING

### 1. INSUFFICIENT WATER ON THE BRUSH

1. Check that the solution filter is not blocked
2. Check the tap beneath the symbol (1) is turned on.
3. Check there is water in the solution tank.

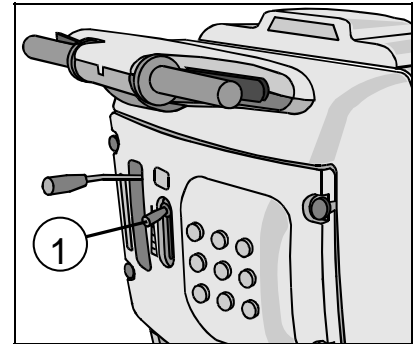

### 2. THE MACHINE DOES NOT CLEAN WELL

1. Check the state of wear and tear of the brush and, if necessary, replace it (the brush must be replaced when the bristles are about 15 mm long).
2. Use a different kind of brush to the one fitted as standard. For cleaning floors where the dirt is particularly resistant, we recommend the use of special brushes supplied upon request and according to needs (see "CHOOSING AND USING THE BRUSHES").

### 3. THE SQUEEGEE DOES NOT DRY PERFECTLY

1. Check that the squeegee rubbers are clean, if dirty clean them, or if worn replace them.
2. Adjust the inclination and height of the squeegee (see the "ADJUSTING THE SQUEEGEE INCLINATION AND HEIGHT" paragraph).
3. Check the suction tube is correctly inserted in its housing on the recovery tank
4. Check the inner filter of the recovery tank is not dirty and, if necessary, clean it thoroughly.
5. Check that the suction motor switch is activated.

### 4. EXCESSIVE FOAM PRODUCTION

Check that a low foam detergent has been used. If necessary, add a small quantity of antifoam liquid to the recovery tank.

Remember that, when the floor is not very dirty, more foam is generated. In this case the detergent solution should be more diluted.

### 6. ELECTRICAL FUSES AND THERMAL PROTECTIONS (SYSTEM E)

The machine is fitted with the following electrical protection systems:  
thermal trip units arranged on the outside of the handlebars, to protect the following motors:

1. Base motor 5 A circuit breaker (1)

In the event of malfunctioning, check a thermal cut-out has not intervened. If the motor overheats, its thermal cut-out intervenes to block the electricity supply. Wait a few minutes until it has cooled down, then press the specific trip unit button to reactivate the power supply and motor operation.



## DISPOSAL

To dispose of the machine, take it to a demolition centre or an authorised collection centre. Before scrapping the machine it is necessary to remove and separate the following materials and send them to the appropriate collection centres in accordance with the environmental hygiene regulations currently in force:

- brushes
- filter
- electric and electronic parts\*
- batteries
- plastic parts (tanks and handlebars)
- metal parts (levers and frame)

(\* ) In particular, to scrap the electric and electronic parts, contact your area distributor

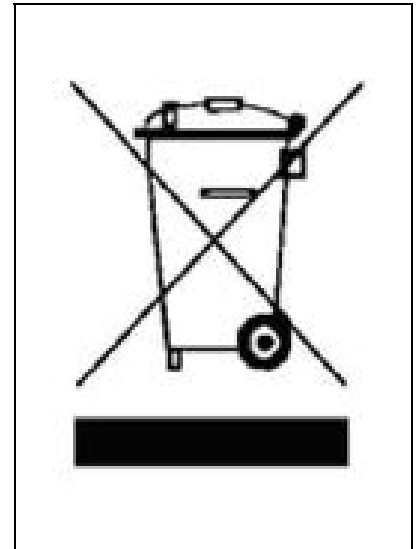





## CHOOSING AND USING THE BRUSHES

### POLYPROPYLENE BRUSH (PPL)

Used on all types of floors. Good resistance to wear and tear, and hot water (no greater than 60°C). The Polypropylene brush is non-hygroscopic and therefore retains its characteristics even when working in wet conditions.

### ABRASIVE BRUSH

The bristles of this type of brush are charged with highly aggressive abrasives. It is used to clean very dirty floors. To avoid floor damage, work only with the pressure strictly necessary.

### THICKNESS OF THE BRISTLES

Thicker bristles are more rigid and are therefore used on smooth floors or floors with small joints.

On uneven floors or those with deep joints, it is advisable to use softer bristles which can enter the gaps more easily.

Remember that when the bristles are worn and therefore too short, they will become rigid and are no longer able to penetrate and clean deep down. In this case, like with overlarge bristles, the brush tends to jump.

### PAD HOLDER

The pad holder is recommended for cleaning shiny surfaces.

There are two types of pad holder:

1. the traditional pad holder is fitted with a series of anchor points that allow the abrasive floor pad to be held and dragged while working
2. the CENTRE LOCK type pad holder not only has anchor points, but also a snap-type central locking system in plastic that allows the abrasive floor pad to be perfectly centred and held without any risk of it becoming detached. This type of dragging device is recommended above all for machines with more than one brush, where the centring of the abrasive discs is difficult.

### TABLE FOR CHOOSING THE BRUSHES

Machine	No. of brushes	Code	Type of bristles	∅ Bristles	∅ Brush	Length	Notes
Minnny 420B		405578	PPL	0.3	210		
		405579	PPL	0.6			
		405580	PPL	0.9			
		414274	ABRASIVE				
		405510	PAD HOLDER				
Minnny 430B-E		414309	PPL	0.3	420		
		414310	PPL	0.6			
		414311	PPL	0.9			
		414312	ABRASIVE				
		405507	PAD HOLDER				
Minnny 500E		427602	PPL	0.3	510		
		427605	PPL	0.6			
		427604	PLL	0.9			
		427708	ABRASIVE				
		405542	PAD HOLDER				
Minnny 520B		405601	PPL	0.3	255		
		405604	PPL	0.6			
		405602	PPL	0.9			
		405603	ABRASIVE				
		405513	PAD HOLDER				
Minnny 530B-E		427602	PPL	0.3	510		
		427605	PPL	0.6			
		427604	PLL	0.9			
		427708	ABRASIVE				
		405542	PAD HOLDER				



## EC DECLARATION OF CONFORMITY

The undersigned company:

**FIMAP S.p.A.**

Via Invalidi del lavoro n.1

37050 Santa Maria di Zevio (VR)

declares under its sole responsibility that the

**FLOOR SCRUBBER-DRYER**

**mod. MINNY 420B – 430B – 520B – 530B**

comply with the requirements of the following Directives:

- 2004/108/EC: Electromagnetic Compatibility Directive and subsequent modifications.
- 2006/42/EC: Machinery Directive
- 2006/95/EC: Low Voltage Directive

They also comply with the following standards:

- EN 60335-1: Household and similar electrical appliances - Safety. Part 1: Generic standards
- EN 60335-2-72: Household and similar electrical appliances. Part 2: Generic standards for automatic machines for floor treatment for commercial and industrial use
- EN 60335-2-29: Household and similar electrical appliances. Part 2: Special standards for battery chargers.
- EN 12100-1: Safety of Machinery - Basic concepts, general principles for design - Part 1: Basic terminology and methodology
- EN 12100-2: Safety of Machinery - Basic concepts, general principles for design - Part 2: Technical principles
- EN 55014-1: Electromagnetic compatibility - Regulations for household appliances, electrical devices and similar equipment. Part 1: Emission - Regulation for product family.
- EN 55014-2: Electromagnetic compatibility - Regulations for household appliances, electrical devices and similar equipment. Part 2: Immunity - Regulation for product family.
- EN 55022: Devices for information technology – Radio interference characteristics – Limits and measurement methods.
- EN 61000-6-2: Electromagnetic compatibility (EMC) - Part 6-2: Generic standards – Immunity for industrial environments.
- EN 61000-6-3: Electromagnetic compatibility (EMC) - Part 6-3: Generic standards – Standard emission for residential, commercial and light-industrial environments.
- EN 61000-3-2: Electromagnetic compatibility (EMC) - Part 3-2: Limits – Limits for harmonic current emissions (Equipment with input current  $\leq 16$  A per phase).
- EN 61000-3-3: Electromagnetic compatibility (EMC) - Part 3-3: Limits – Restriction of voltage variations and flicker in low voltage power supply systems for devices with a rated current  $\leq 16$  A.
- EN 62233: Household and similar electrical appliances - Electromagnetic fields Methods for evaluation and measurement

The person authorised to compile the technical file:

Sig. Giancarlo Ruffo

Via Invalidi del Lavoro, 1

37050 Santa Maria di Zevio (VR) - ITALY

San Giovanni Lupatoto, 27/09/2010

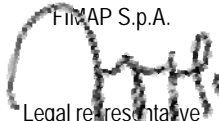
FIMAP S.p.A.  
  
Legal representative

Giancarlo Ruffo

**Manufacturer: FIMAP (SHANGHAI) MACHINES Ltd.**

N. 518 DONXUE RD. DONGJING INDUSTRIAL ZONE  
201619 SONGJIANG DISTRICT – SHANGHAI – PRC  
Tel. +86 21 57670862 - Fax +86 21 57670863

**Agent: FIMAP spa**

Via Invalidi del Lavoro, 1 – 37050 Santa Maria di Zevio (VR) ITALY  
Tel. +39 045 6060411 r.a. – Fax +39 045 6060417  
e-mail: [fimap@fimap.com](mailto:fimap@fimap.com) - [www.fimap.com](http://www.fimap.com)



## EC DECLARATION OF CONFORMITY

The undersigned company:

**FIMAP S.p.A.**

Via Invalidi del Lavoro no.1

37050 Santa maria di Zevio (VR)

declares under its sole responsibility that the

**FLOOR SCRUBBER-DRYER**

**mod. MINNY 430E – 500E – 530E**

comply with the requirements of the following Directives:

- 2004/108/EC: Electromagnetic Compatibility Directive and subsequent modifications.
- 2006/95/EC: Low Voltage Directive
- 2006/42/EC: Machinery Directive

They also comply with the following standards:

- EN 60335-1: Household and similar electrical appliances - Safety. Part 1: Generic standards
- EN 60335-2-72: Household and similar electrical appliances. Part 2: Generic standards for automatic machines for floor treatment for commercial and industrial use
- EN 12100-1: Safety of Machinery - Basic concepts, general principles for design - Part 1: Basic terminology and methodology
- EN 12100-2: Safety of Machinery - Basic concepts, general principles for design - Part 2: Technical principles
- EN 55014-1: Electromagnetic compatibility - Regulations for household appliances, electrical devices and similar equipment. Part 1: Emission - Regulation for product family.
- EN 55014-2: Electromagnetic compatibility - Regulations for household appliances, electrical devices and similar equipment. Part 2: Immunity - Regulation for product family.
- EN 61000-6-1: Electromagnetic compatibility (EMC) - Part 6-1: Generic standards - Immunity for residential, commercial and light-industrial environments
- EN 55022: Devices for information technology – Radio interference characteristics – Limits and measurement methods.
- EN 61000-6-2: Electromagnetic compatibility (EMC) - Part 6-2: Generic standards – Immunity for industrial environments.
- EN 61000-6-3: Electromagnetic compatibility (EMC) - Part 6-3: Generic standards — Standard emission for residential, commercial and light-industrial environments.
- EN 61000-3-2: Electromagnetic compatibility (EMC) - Part 3-2: Limits – Limits for harmonic current emissions (Equipment with input current  $\leq 16$  A per phase).
- EN 61000-3-3: Electromagnetic compatibility (EMC) - Part 3-3: Limits – Restriction of voltage variations and flicker in low voltage power supply systems for devices with a rated current  $\leq 16$  A.
- EN 62233: Household and similar electrical appliances - Electromagnetic fields Methods for evaluation and measurement

The person authorised to compile the technical file:

Sig. Giancarlo Ruffo

Via Invalidi del Lavoro, 1

37050 Santa Maria di Zevio (VR) - ITALY

San Giovanni Lupatoto, 27/09/2010

FIMAP S.p.A.



Legal representative

Giancarlo Ruffo